

The S-series Eletta Flow Monitor

with direct reading and dual
adjustable flow contacts



Eletta flow

when you want to know



S-GL series

The Pipe Section is constructed of copper alloy and fitted with BSP/ NPT threads from 15 mm to 40 mm (1/2"–1 1/2").



S-FA series

The Pipe Section has a flanged (wafer) process pipe connection and the material is bronze from 15 mm up to size 40 mm (1/2"–1 1/2") and epoxy polyester coated cast iron in sizes 50 mm to 400 mm (2"–16").

Benefits of the S-series

- **Rugged and sturdy design**
- **Uses proven differential pressure technique**
- **Economical alternative to expensive flow meters**
- **Liquids and gases can be monitored**
- **Large 120 mm dial with linear scale for direct reading**
- **Two SPDT micro switches for adjustable flow alarm**
- **Insensitive to magnetic fields**
- **Available also as direct reading flow monitor S02/S05**

Important applications and product features

- Monitoring flows in cooling and lubricating circuits
- Antifreeze protection of heat pump systems
- Dry out protection
- Starting and stopping pump motors
- Shows flow without external power
- Low cost solution for difficult flow applications
- Interchangeable control units to fit all pipe sections
- Not affected by static pressure



S-GSS series

The Pipe Section is made from Stainless Steel and comes with BSP/NPT threads in size 15, 20 and 25 mm (1/2", 3/4" and 1").



S-FSS series

The Pipe Section comes in stainless steel and has the same "fit between flanges" (wafer) execution as the -FA series and process connections from 15 mm to 500 mm (1/2"-20").

The S-series Flow Monitor

The Eletta Flow Monitor's function is based on the proven and dependable differential pressure principle. This is perhaps the oldest and most widely used principle for flow metering, mainly because of its simplicity and its relatively low cost.

The S-series Flow Monitor is used to monitor and control the flow of liquids and gases in pipes from 15 mm to 500 mm. The direct reading S-series has a large and easy readable 130 mm dial with a linear scale as standard and it can be fitted with a customized scale as an option. It is ideally suited for harsh and dusty industrial environments where its sturdy and robust design are appreciated. In addition, it is possible through the two independently adjustable SPDT micro switches, to set a low and/or high flow alarm to protect expensive equipment in various piping systems. The Monitor is insensitive to surrounding magnetic fields and it combines the long-standing proven mechanical function with outstanding reliability. Together with an exceptionally sturdy and robust design, this makes it extremely well suited for difficult environments. The S-series can also be ordered without the micro switches, designated **S02** and **S05**, and is then used as a direct reading flow monitor only.

The S-series comes in two measuring ratios designated **S2/S02** and **S25/S05**, which means that the **S2/S02** has a measuring span of 1:2 and the **S25/S05** has a span of 1:5.

Like all Eletta Flow Monitors the S-series can monitor both liquids and gases.

Modular design

All the Eletta Flow Monitors including the S-series can be fitted to any of the various Eletta Flow Monitor Pipe Sections to suit your application.

The Instrument consists of two parts mainly, i.e. the Pipe Section and the Control Unit. The Pipe Section is the part that is to be mounted in the process pipe and the Control Unit is mounted directly (standard) or remote onto the Pipe Section.

As the Control Unit is pre-calibrated before leaving our production facilities, you can change pipe sections in the field to fit other dimensions and materials than originally ordered without recalibration.

The Control Unit contains the two micro switches which, can be adjusted independently in the field within the measuring range for both high and low alarm.

The Pipe Sections come in Copper alloy, Stainless Steel, Cast Iron and sizes from DN 15/PN 16 (ANSI 1/2"/150 lbs) up to DN 500/PN 16 (ANSI 20"/150 lbs). The S-series Control Unit can also be used independently to upgrade an already installed Eletta Flow Monitor, such as A-, V- or R-models even after the installation.

Specifications S-series

Flow range:	0,4–25 000 l/min (liquid)
Min. flow:	S2 and S02: 50% of the full scale flow range S25 and S05: 20% of the full scale flow range
Wetted materials:	Copper alloy, epoxy painted cast iron. Seaworthy stainless steel 904L, stainless steel, 316
Rubber parts:	Nitrile (HNBR), EPDM and Fluorinated rubber (FPM)
Max. pressure:	16 bar (232 PSI)
Standards:	PN 16/ANSI 150 lbs
Max. temp. Control Unit:	90°C standard, 120°C optional.
Max. temp. Pipe Section:	-GL and -FA: 120°C (248°F) -GSS, -FSS: 250°C (482°F)
Enclosure:	IP43 (NEMA3R) std. IP65 (NEMA4) option
Dial:	Large 120 mm diameter with linear scale and front glass of acrylic
Process Connection:	DN 15–40, BSP/NPT thread DN 15–500 DIN/ANSI flange (wafer)
Alarm:	S2 and S25 has 2 (two) micro switch SPDT contacts, independently adjustable within the ordered Flow range. S02 and S05 comes without swithes
Micro switch spec:	Contact surfaces are silver plated as standard. Type: SPDT Hystereses: 10% Rated voltage: 480 VAC/15A Breaking current: 15@125, 250, 480 VAC Resistive load: 2A@30 VDC 0,4A@125 VDC 0,2A@230 VDC
Accuracy:	<+/-5% F.S within 20–80% of Flow range <+/-10% F.S within 100% of Flow range
Repeatability:	<2% actual
CE-approvals:	The Eletta Flow Monitors and Meters conforms with all the EU directives applicable for our products. Certificates can be found on our website; www.eletta.com .



Eletta Flow Monitors

The name Eletta has become synonymous with flow monitoring in many industries world wide where the Products are appreciated for their sturdy and robust design.

Eletta Flow Monitors are of our own proprietary design and our manufacturing as well as the whole company is certified to ISO 9001 and ISO 14000 quality standards.

We export our Products all over the world and we have Authorized Distributors in most European countries, Australia, South Africa, India, Japan and USA.

Find out more

In our technical leaflets and manuals you will find full details of the design, pressure drop graphs, measuring ranges and dimensional drawings. We welcome you to our at all time updated web site at www.eletta.com for the most recent and accurate information about Eletta and our Products. At this site you can find most of the documentation on down-loadable files. Whatever your request for information is, our e-mail address:

info@eletta.com is the fastest way to get in contact with our Customer Support and technical department. Of course, your local Eletta Distributor, whose address you can find in our homepage, can assist you in most cases.

ELETTA

— FLOW MONITORS —

Eletta Flow AB

Box 5084, SE-141 05 Kungens Kurva, Sweden

Tel. +46 8 603 07 70 •

info@eletta.com

www.eletta.com

Measuring Ranges

Eletta Flow Monitors

D2, V1, S02, S2, R2 and A2			
Dim. DN		lit/min	MCx(S2)
1/2" DN 15	GL,GSS FA, FSS	0,4 – 0,8	0,1
		0,6 – 1,2	0,15
		1 – 2	0,25
		1,6 – 3,2	0,4
		2 – 4	0,5
		2,4 – 4,8	0,6
		3,2 – 6,4	0,8
		4 – 8	1
		6 – 12	1,5
		8 – 16	2
		10 – 20	2,5
		12 – 24	3
16 – 32	4		
3/4" DN 20	GL,GSS FA, FSS	4 – 8	1
		6 – 12	1,5
		8 – 16	2
		10 – 20	2,5
		12 – 24	3
		16 – 32	4
20 – 40	5		
1" DN 25	GL,GSS FA, FSS	8 – 16	2
		10 – 20	2,5
		12 – 24	3
		16 – 32	4
		24 – 48	6
		36 – 72	9
		40 – 80	10
	FA, FSS	50 – 100	12,5
1 1/4" DN 32	FA, FSS	20 – 40	5
		28 – 56	7
		40 – 80	10
		60 – 120	15
		80 – 160	20
1 1/2" DN 40	GL, FA, FSS	20 – 40	5
		28 – 56	7
		40 – 80	10
		60 – 120	15
		80 – 160	20
			FA, FSS
2" DN 50	FA, FSS	40 – 80	10
		60 – 120	15
		80 – 160	20
		120 – 240	30
		160 – 320	40
2 1/2" DN 65	FA, FSS	60 – 120	15
		80 – 160	20
		120 – 240	30
		160 – 320	40
		240 – 480	60
		280 – 560	70
3" DN 80	FA, FSS	120 – 240	30
		160 – 320	40
		240 – 480	60
		320 – 640	80
		400 – 800	100
4" DN 100	FA, FSS	160 – 320	40
		280 – 560	70
		400 – 800	100
		600 – 1200	150
		700 – 1400	175
5" DN 125	FA, FSS	400 – 800	100
		600 – 1200	150
		800 – 1600	200
		1000 – 2000	250
6" DN 150	FA, FSS	600 – 1200	150
		800 – 1600	200
		1200 – 2400	300
		1400 – 2800	350
		1500 – 3000	375
8" DN 200	FA, FSS	800 – 1600	200
		1200 – 2400	300
		1600 – 3200	400
		2400 – 4800	600
		2500 – 5000	625
10" DN 250	FA, FSS	1600 – 3200	400
		2000 – 4000	500
		3200 – 6400	800
		4000 – 8000	1000



D5, V15, S05, S25, R5 and A5

Dim. DN		lit/min	MCx(S25)
1/2" DN 15	GL,GSS FA, FSS	0,4 – 2	0,4
		1 – 5	1
		2 – 10	2
		4 – 20	4
		6 – 30	6
		8 – 40	8
3/4" DN 20	GL, GSS FA, FSS	4 – 20	4
		6 – 30	6
		8 – 40	8
		15 – 75	15
1" DN 25	GL, GSS FA, FSS	6 – 30	6
		12 – 60	12
		16 – 80	16
		24 – 120	24
	FA, FSS	30 – 150	30
1 1/4" DN 32	FA, FSS	8 – 40	8
		20 – 100	20
		40 – 200	40
		50 – 250	50
1 1/2" DN 40	GL, FA, FSS	8 – 40	8
		20 – 100	20
		40 – 200	40
		60 – 300	60
2" DN 50	FA, FSS	20 – 100	20
		40 – 200	40
		70 – 350	70
		100 – 500	100
2 1/2" DN 65	FA, FSS	20 – 100	20
		50 – 250	50
		100 – 500	100
		160 – 800	160
3" DN 80	FA, FSS	40 – 200	40
		80 – 400	80
		160 – 800	160
		240 – 1200	240
4" DN 100	FA, FSS	80 – 400	80
		160 – 800	160
		250 – 1250	250
		400 – 2000	400
5" DN 125	FA, FSS	100 – 500	100
		200 – 1000	200
		400 – 2000	400
		600 – 3000	600
6" DN 150	FA, FSS	200 – 1000	200
		400 – 2000	400
		600 – 3000	600
		900 – 4500	900
8" DN 200	FA, FSS	400 – 2000	400
		600 – 3000	600
		1000 – 5000	1000
		1500 – 7500	1500
10" DN 250	FA, FSS	600 – 3000	600
		1000 – 5000	1000
		1600 – 8000	1600
		2400 – 12000	2400

MC = Measuring Constant

It is possible to order a lower measuring range than indicated



FLOW MONITORS

Eletta Flow AB

Box 5084, SE-141 05 Kungens Kurva, Sweden
Tel. +46 8 603 07 70 • Fax. + 46 8 646 10 40
info@eletta.com • www.eletta.com

Weight and Dimensions



D, V- GL						
Type	D	A mm	B mm	C mm	E mm	Weight kg*
-GL15	1/2"	75	150	30	80	3,0
-GL20	3/4	75	150	30	80	3,0
-GL25	1"	75	150	30	80	3,0
-GL40	1 1/2"	85	160	40	90	4,0

D, V- FA					
Type	d mm	D mm	A mm	Width mm	Weight kg*
-FA15	16 (1/2")	53	150	70	4,0
-FA20	22 (3/4")	63	154	70	4,5
-FA25	30 (1")	73	161	70	4,5
-FA32	39 (1 1/4")	84	167	70	5,0
-FA40	43 (1 1/2")	94	172	70	6,0
-FA50	55 (2")	109	180	70	6,0
-FA65	70 (2 1/2")	129	190	70	7,0
-FA80	82 (3")	144	197	70	8,0
-FA100	107 (4")	164	207	70	8,0
-FA125	132 (5")	194	222	70	10,0
-FA150	159 (6")	219	235	70	11,0
-FA200	207 (8")	274	263	70	15,0
-FA250	260 (10")	330	290	70	19,0
-FA300	310 (12")	385	320	70	21,0
-FA350	340 (14")	445	345	70	35,0
-FA400	390 (16")	498	375	70	40,5

D, V- GSS					
Type	D	A mm	B mm	C mm	Weight kg*
-GSS15	1/2"	100	130	35	3,0
-GSS20	3/4"	100	130	35	3,0
-GSS25	1"	100	130	35	3,0

D, V- FSS					
Type	d mm	D mm	A mm	Width mm	Weight kg*
-FSS15	16 (1/2")	53	169	15	3,0
-FSS20	22 (3/4")	63	175	15	3,0
-FSS25	30 (1")	73	183	15	3,0
-FSS32	39 (1 1/4")	84	185	15	3,0
-FSS40	43 (1 1/2")	94	190	15	3,0
-FSS50	55 (2")	109	210	15	3,0
-FSS65	70 (2 1/2")	129	220	15	3,5
-FSS80	82 (3")	144	228	15	3,5
-FSS100	107 (4")	164	238	15	4,0
-FSS125	132 (5")	194	253	15	4,5
-FSS150	159 (6")	219	266	15	5,0
-FSS200	207 (8")	274	293	15	6,5
-FSS250	260 (10")	330	320	15	8,0
-FSS300	310 (12")	385	350	15	9,5
-FSS350	340 (14")	445	375	18	14,5
-FSS400	390 (16")	498	405	18	16,5

S- GL						
Type	D	A mm	B mm	C mm	E mm	Weight kg*
-GL15	1/2"	85	150	30	80	3,5
-GL20	3/4	85	150	30	80	3,5
-GL25	1"	85	150	30	80	3,5
-GL40	1 1/2"	95	160	40	90	4,5

S- FA					
Type	d mm	D mm	A mm	Width mm	Weight kg*
-FA15	16 (1/2")	53	160	70	4,5
-FA20	22 (3/4")	63	164	70	5,0
-FA25	30 (1")	73	171	70	5,0
-FA32	39 (1 1/4")	84	177	70	5,5
-FA40	43 (1 1/2")	94	182	70	6,5
-FA50	55 (2")	109	190	70	6,5
-FA65	70 (2 1/2")	129	200	70	7,5
-FA80	82 (3")	144	207	70	8,0
-FA100	107 (4")	164	217	70	9,0
-FA125	132 (5")	194	232	70	11,0
-FA150	159 (6")	219	245	70	11,0
-FA200	207 (8")	274	273	70	15,5
-FA250	260 (10")	330	300	70	19,0
-FA300	310 (12")	385	330	70	22,0
-FA350	340 (14")	445	355	70	35,5
-FA400	390 (16")	498	385	70	41,0

S- GSS					
Type	D	A mm	B mm	C mm	Weight kg*
-GSS15	1/2"	110	130	35	3,0
-GSS20	3/4"	110	130	35	3,0
-GSS25	1"	110	130	35	3,0

S- FSS					
Type	d mm	D mm	A mm	Width mm	Weight kg*
-FSS15	16 (1/2")	53	179	15	3,0
-FSS20	22 (3/4")	63	185	15	3,0
-FSS25	30 (1")	73	193	15	3,5
-FSS32	39 (1 1/4")	84	200	15	3,5
-FSS40	43 (1 1/2")	94	205	15	3,5
-FSS50	55 (2")	109	220	15	4,0
-FSS65	70 (2 1/2")	129	230	15	4,0
-FSS80	82 (3")	144	238	15	4,0
-FSS100	107 (4")	164	248	15	4,5
-FSS125	132 (5")	194	263	15	5,0
-FSS150	159 (6")	219	276	15	5,5
-FSS200	207 (8")	274	303	15	7,0
-FSS250	260 (10")	330	330	15	9,0
-FSS300	310 (12")	385	355	15	10,0
-FSS350	340 (14")	445	385	18	15,0
-FSS400	390 (16")	498	415	18	17,0

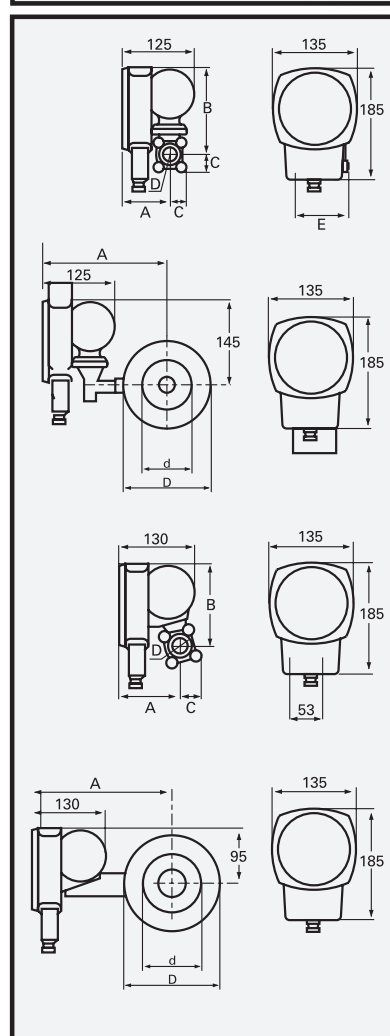
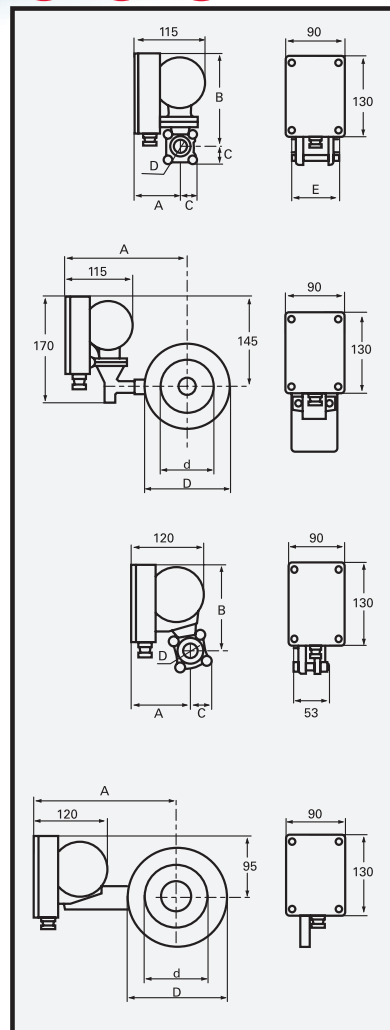

Width see table
*Approximate weight

To specify upon ordering: S-series



S02/S2-GL
S05/S25-GL



S02/S2-FA
S05/S25-FA



S02/S2-GSS
S05/S25-GSS



S02/S2-FSS
S05/S25-FSS

1. Type of monitor
2. Dimension
3. Measuring range
4. Media:

For water no further info required, go to item 5.

For oil specify type of oil, working temp or viscosity and density and working temperature

NOTE: If no data are given calculation will be done acc to: ISO VG 220@40°C

For gas specify type of gas, working temp and static pressure

5. Flow direction alternative

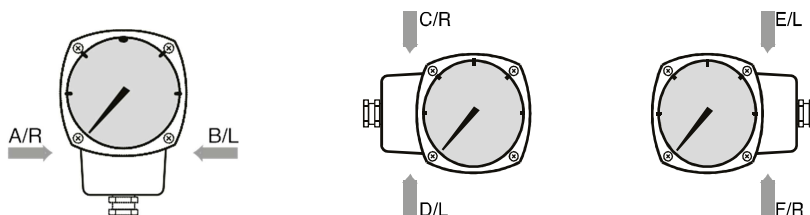

Example: S2-GL, dimension DN15, range 4 – 8 l/min, media water, inst A/R

Options:

- High temp version 120 C (only for S2/S25)
- Goldplated switches (only for S2/S25)
- SPDT switch split contact (only for S2/S25)
- Direct reading dial (eg. l/min, m3/h etc)
- Protection class IP65 (NEMA 4)
- Chemical Nickel plating (for GL only)
- Customized alarm set point
- Mark on tag plate (max. 21 characters)
- ANSI connection
- Rubber parts in other material
- Separate mounting
- Manifold with shut-off valves
- Forced production time